



BASCO[®]
ENGINEERED
SHELL & TUBE
HEAT EXCHANGERS

API Heat Transfer

...world leaders in heat transfer technology



...a name synonymous with high quality, cost effective shell & tube heat exchangers for over 60 years.

With a proud tradition of service to both OEM and End User customers, API Heat Transfer's Basco division has successfully met industry's most challenging heat transfer applications with robust, cost effective designs that endure the test of time.

API Heat Transfer is your one source for custom engineered shell & tube heat exchangers. With sizes ranging from 3" to 144" in diameter, and 12" to 40' in length, our API Basco division is a full service manufacturer. Combining our human talent with our state-of-the-art manufacturing facility, our applications expertise with our mechanical design know-how, and our drive to be the best means our customers get what they pay for and more.

Application Engineering

Our highly knowledgeable and experienced staff of application engineers use state-of-the-art software technology including HYSIM, ASPEN (B-JAC) and HTRI as well as proprietary rating systems developed in-house. Combining API Basco's engineering know-how with sophisticated software tools ensures the best solution for each application. Heat loads, pressure drop restrictions, phase change, materials of construction, numerous international code requirements, and customer specifications are only some of the criteria our engineers assess on every project.

After thorough review of all the parameters, a complete professional proposal is generated for the appropriate Basco/Whitlock Shell & Tube design.

Mechanical Engineering

API Basco employs a full mechanical design team to handle all contract work. Well versed in ASME, PED, and Chinese CML Codes, as well as other regional pressure vessel regulations, our designers ensure accuracy of drawings using the latest 2-D and 3-D modeling software. Developing accurate bills of material, producing all necessary code calculations, and ensuring proper completion of all required code paperwork and inspection reports are all part of the daily activities for this team of design professionals.



Advanced Pressure



Autocad



Cosmosworks FEA



ANSYS FEA



STXWin



B-JAC



HTRI



Solid Works

Manufacturing

API Basco is located in Buffalo, NY within a few miles of major highway, air and rail transportation. Our 132,000 sq. ft.



manufacturing space is ISO 9001 certified and houses extensive fabrication resources including various CNC drilling and machining centers, turning centers, and CNC punch presses. Multiple bridge and jib cranes, a multi-media blast facility, burning

table, tube bending equipment, and a vast array of other support equipment are employed to manufacture high quality, custom shell & tube heat exchangers.

Inspection and Test

Each stage of manufacturing is subjected to rigorous inspection and test scrutiny – from incoming material to completed assembly.



A resident ASME authorized inspector oversees the complete manufacturing operation. Our in-house quality team ensures that the proper procedures are in-place, that our employees are well trained, and that all the required inspections occur at the critical stages of assembly. API Basco is well versed in all major pressure vessel codes, invests regularly in maintaining our various code certifications and can offer a wide range of testing typical within the shell & tube industry.

Product Development

API Heat Transfer invests continuously to stay at the forefront of technology. Our product development staff and on-site test facility distinguishes API Heat Transfer from many of our peers. We believe a strong focus on new products adds real value for our customers. By working closely with our customers during their new product development or product redesign cycle, API Heat Transfer can provide a solution that optimizes thermal efficiency, pressure loss, size, weight and price to provide the best overall value.

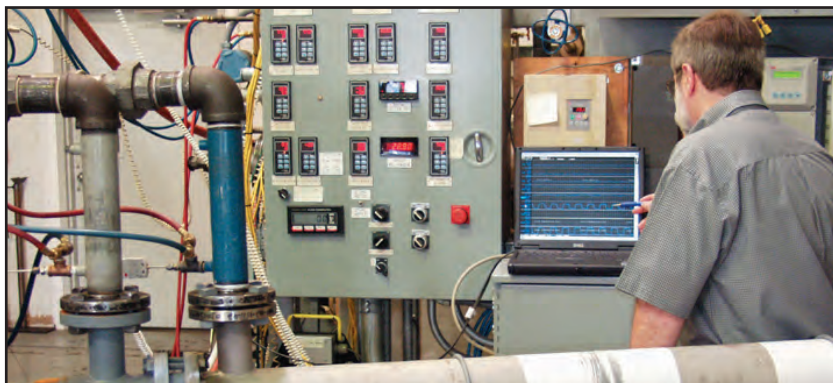

Markets Served Include:

Air Separation

Chemical

Compressor

Electronics

Fluid Power

Industrial

Marine

Nuclear

Pharmaceutical

Plastics

Power Generation

Pulp & Paper

Refrigeration

Engineering Capabilities

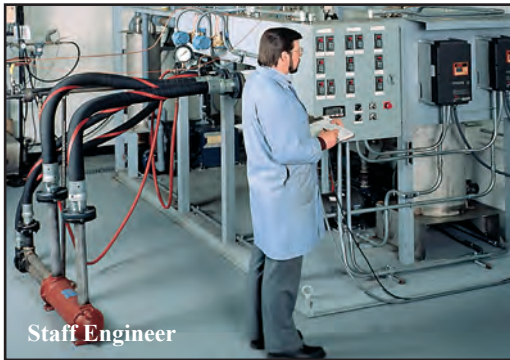

In-House Resources

- Degreed staff engineers
- Applications expertise
- Mechanical design know-how
- Product development capabilities

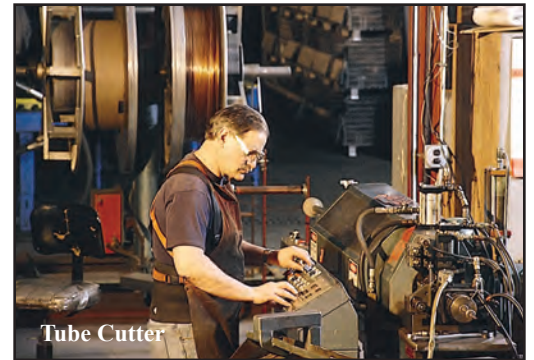

Code Capabilities

- ASME Section VIII
- PED
- TUV
- Chinese CML
- ASME Section I
- TEMA C, B & R
- Canadian Registration
- Australian AS-1210
- Polish UDT
- Korean Factory Registration



Software

- HTRI
- ASPEN (B-JAC)
- FEA
- 3-D Modeling
- CFD - Computational Fluid Dynamics
- HYSIM Process Modeling
- In-house engineering software development

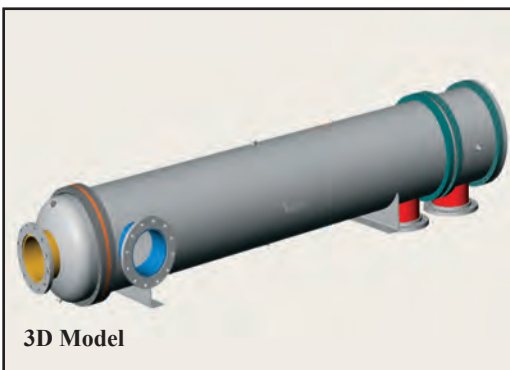

Product Development

- Performance testing
- Fatigue testing
- Thermal cycling
- Prototype development
- Thermal software development

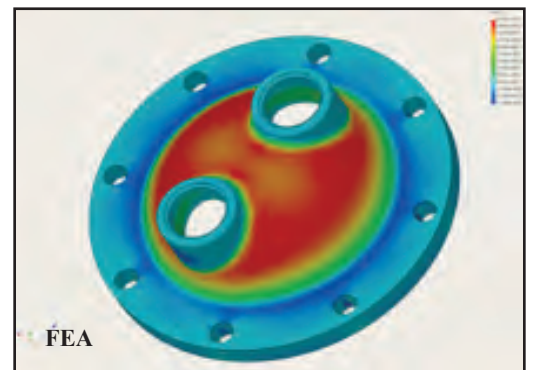

Manufacturing Capabilities



Manufacturing Skills

- Torque control rolling
- Seal and strength welding
- Polishing, Sanitary 3A
- TIG, MIG, GMAW, GTAW, SAW and SMAW welding techniques
- TEMA tight drilling tolerances



Quality Assurance

- X-ray
- Magnetic particle
- Heat treatment
- ISO 9001
- Resident ASME code inspector
- Helium leak testing
- Impact testing
- PMI



Major Equipment

- CNC drilling centers
- CNC machining centers
- CNC turning centers
- CNC punch press
- (1) 100-ton bridge crane
- (5) 20-ton bridge cranes
- Plasma burning tables
- Tube bender
- Multi-media blast facilities
- High capacity air dryer
- Plate fin press



Special Services

- Oil flushing
- Hydro testing
- Pneumatic testing
- Oxygen cleaning
- Drying
- Special paint



Basco People & Solutions



**API Basco Shop
Bundle Assembly Area**

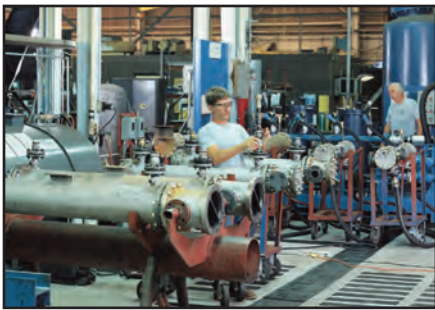

**API Basco Shop
Type OP Assembly Area**



Team Basco



**Evaporator with
Disengagement Drum**

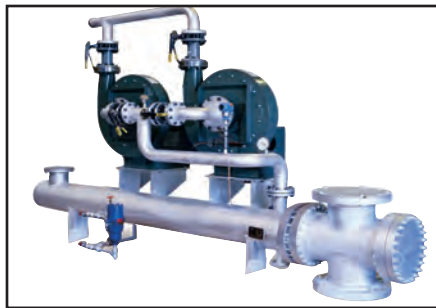

**Gland Condenser
Package**

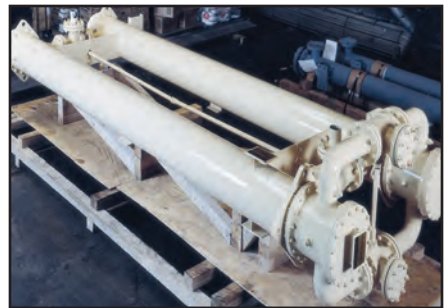

**Stacked TEMA AEW's
with Transfer Values**



**TEMA BEU Exchanger for
Wastewater Treatment**

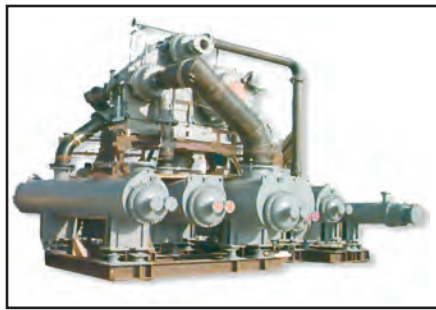

**TYPE ES Intercoolers on
a Compressor Package**

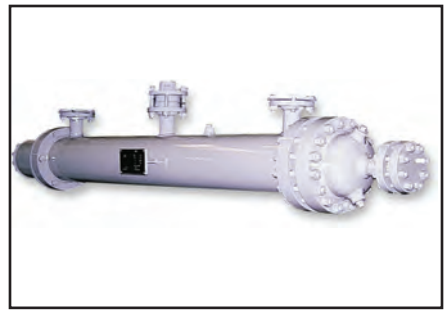

High Pressure TEMA BEP

Providing Custom Thermal Solutions!

TEMA Shell & Tube Nomenclature

API Basco is a proud member of TEMA - Tubular Exchanger Manufacturer's Association. TEMA members set the standards by which virtually all custom shell & tube heat exchangers are specified and built. Basco has been a member since the 1950's, and consequently we have a complete and comprehensive understanding of the engineering, manufacturing and testing requirements to meet this world-recognized standard. While other manufacturers may simply interpret the regulations, API Basco has the requisite member design and fabrication capabilities to lead the industry by helping to shape and define those standards for the long-term benefit of all users.



FRONT END STATIONARY HEAD TYPES		SHELL TYPES		REAR END HEAD TYPES	
A	 CHANNEL AND REMOVABLE COVER	E	 ONE PASS SHELL	L	 FIXED TUBESHEET LIKE "A" STATIONARY HEAD
B	 BONNET (INTEGRAL COVER)	F	 TWO PASS SHELL WITH LONGITUDINAL BAFFLE	M	 FIXED TUBESHEET LIKE "B" STATIONARY HEAD
C	 REMOVABLE TUBE BUNDLE ONLY CHANNEL INTEGRAL WITH TUBE-SHEET AND REMOVABLE COVER	G	 SPLIT FLOW	N	 FIXED TUBESHEET LIKE "N" STATIONARY HEAD
N	 CHANNEL INTEGRAL WITH TUBE-SHEET AND REMOVABLE COVER	H	 DOUBLE SPLIT FLOW	P	 OUTSIDE PACKED FLOATING HEAD
D	 SPECIAL HIGH PRESSURE CLOSURE	J	 DIVIDED FLOW	S	 FLOATING HEAD WITH BACKING DEVICE
		K	 KETTLE TYPE REBOILER	T	 PULL THROUGH FLOATING HEAD
		X	 CROSS FLOW	U	 U-TUBE BUNDLE
				W	 EXTERNALLY SEALED FLOATING TUBESHEET

TEMA Shell & Tube Specifications

TEMA BET

Description: Pull through tube bundle □ studded internal floating head to tubesheet joint □ multi-pass tubeside or single pass with Slip Tube design □ channel or bonnet tubeside connection □ pressure range – 75 psi to 300 psi.

Applications: Liquid heaters with low pressure steam on the shell side □ single and double shell (gas in shell) compressor intercoolers on refinery applications □ shellside gas or oil coolers.

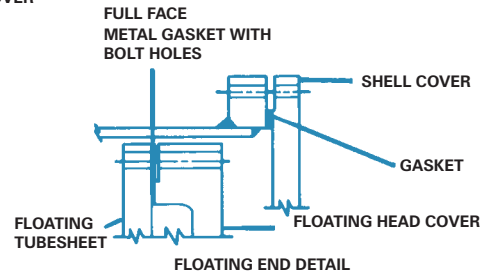
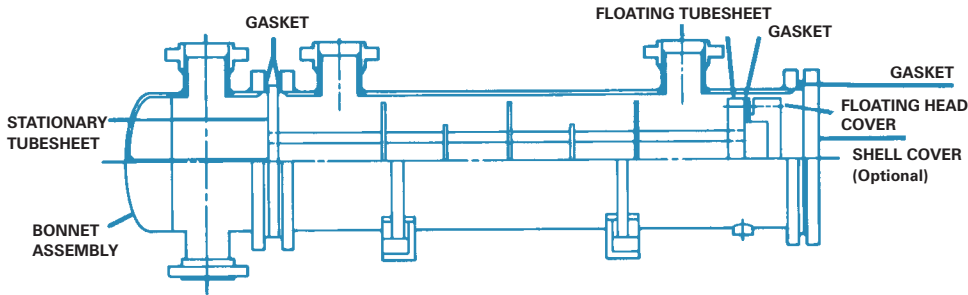

Advantages:

1. Relatively large annulus around outer tube limit (O.T.L.) and shell I.D. permits entrance to the tube bundle with little resistance. The results are low entrance-exit velocities and pressure loss.
2. Easily removable tube bundle.
3. Tube bundle expands freely with no special provisions for expansion.

Limitations:

1. No gasket leak detection at floating head and tubesheet.
2. Relatively low thermal efficiency due to large annulus between outer tube limit (O.T.L.) and shell I.D. (results in low shell side heat transfer coefficient).
3. Less tubes for any given shell size compared to other types.

TEMA AES

Description: Removable tube bundle, split clamp-ring floating head □ multi-pass tubeside or single pass with Slip Tube design □ floating head bolted to split clamp-ring (requires shell cover larger than shell to accommodate floating head) □ pressure range – 75 psi to 600 psi.

Applications: Often used in refineries □ gas in shell units up to 600 psi □ high pressure seal oil coolers up to 600 psi □ API 660 oil coolers.

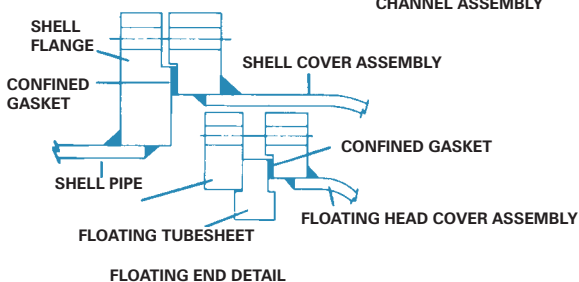
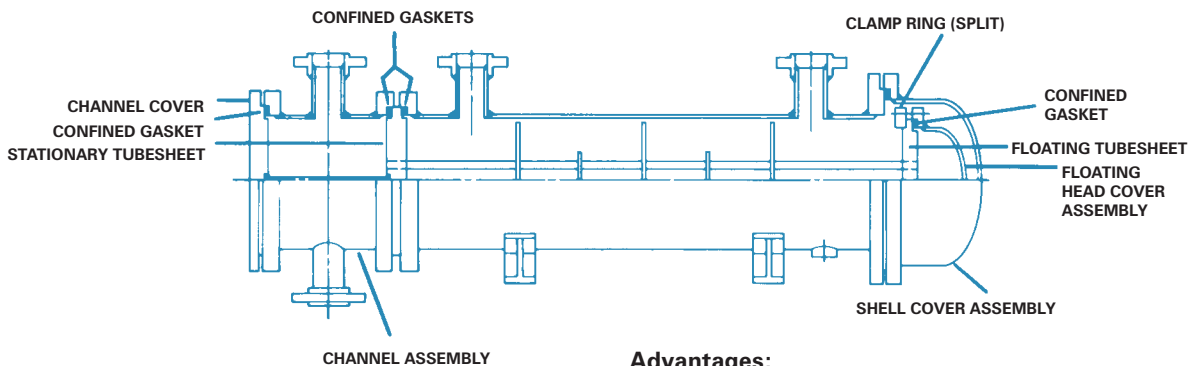

Advantages:

1. Higher efficiency compared to Type BET units because of smaller annulus and more tubes per shell size.
2. Tube bundle expands freely with no special provisions for expansion.

Limitations:

1. No gasket leak detection at floating head.
2. Floating head and fixed end connection must be unbolted to remove tube bundle.

TEMA Shell & Tube Specifications

TEMA BEP

Description: Removable tube bundle, outside packed floating tubesheet design. Tubesheet assembly may be of fabricated or forged steel to satisfy design pressure requirements □ tubeside fluid is fully gasketed; shellside packing available in various materials □ tubeside pressure range – to 3000 psi. Max 150 psi shellside.

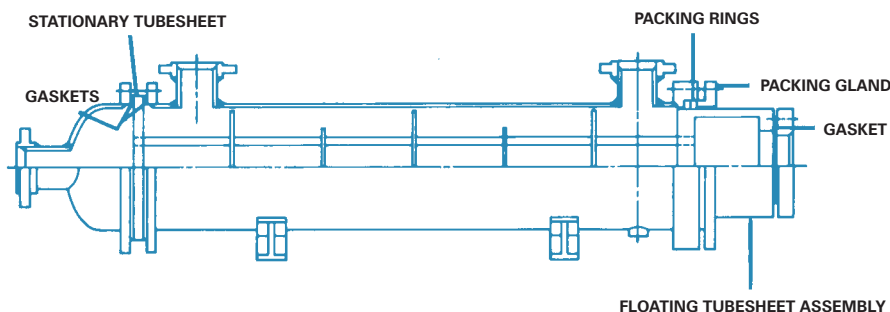

Applications: Where lethal or explosive gasses are involved □ where high pressure is applied only on the tubeside □ where gasket malfunction must be detectable.

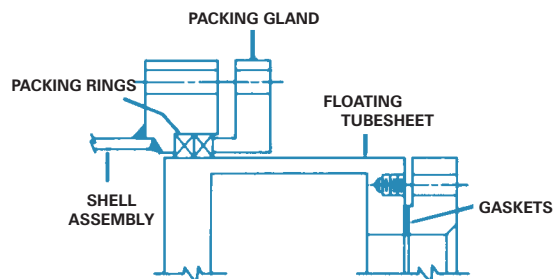

Advantages:

1. No packing exposed to tubeside fluid.
2. Compared to BET and BES, outer tube limit (O.T.L.) relatively close to shell I.D. resulting in increased heat transfer efficiency.
3. No possibility of shell and tubeside fluids intermixing through packing or gaskets.

Limitations:

1. One or two pass configurations only.
2. Shellside pressure up to 150 psi because of packing rings at floating tubesheet head.
3. Bundle expands into customer's piping.

TEMA BEM

Description: Fixed tubesheet, non-removable bundle □ tubesheet welded directly to shell □ single or multi-pass design.

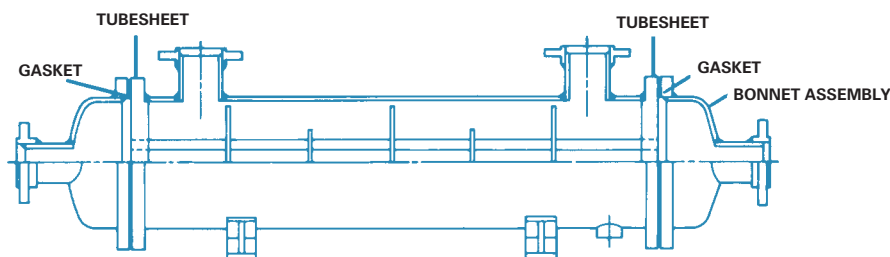

Applications: Chemical processes □ high pressure air and nitrogen chillers (gas in tubes, freon shellside).

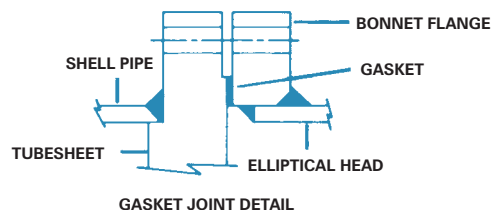

Advantages:

1. Economical design.
2. No possibility of contamination compared to designs with floating head gaskets (except in tube failures).
3. High pressure shellside designs more easily accomplished than in floating head types.
4. Extremely efficient shellside heat transfer due to small annulus between outer tube limit (O.T.I.) and shell I.D.
5. Shell design can be modified for large expansion area where partial vaporization of liquid occurs.
6. No gasketed joints on shellside.

Limitations:

1. No provisions for differential expansion of tubes and shell without expansion joint.
2. Shell and tubesheet material must be weldable.
3. Tube bundle is not removable for cleaning.

TEMA Shell & Tube Specifications

TEMA BEU

Description: U-tube design with pull through, removable or non-removable tube bundle □ furnished in multi-pass design only □ pressure range – 75 psi to 3000 psi tubeside and 75 psi to 1500 psi shellside.

Applications: Chemical processes □ tank suction heater □ liquid heaters □ vaporizers (where partial vaporization of liquid occurs).

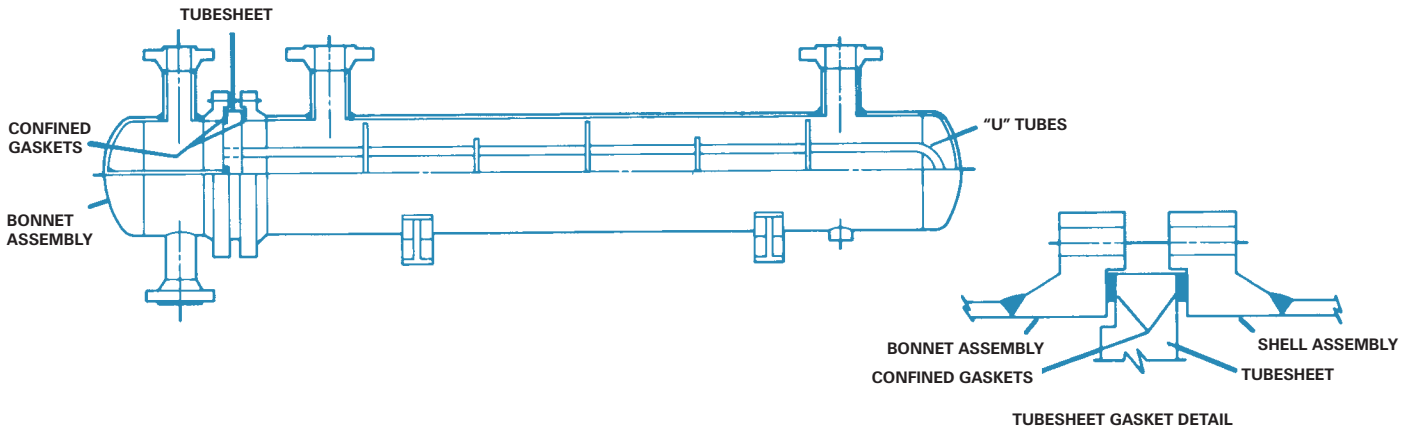

Advantages:

1. Tubes expand freely without special provisions.
2. Single tubesheet minimizes number of tubeside joints.
3. Economical construction.
4. Highly efficient heat transfer – small annulus between outer tube limit (O.T.L.) and shell I.D.
5. Tube bundle easily removable.

Limitations:

1. Outer tube rows must be removed before replacing inner rows.
2. Requires chemical cleaning.
3. May not be advisable for use where tubeside fouling is anticipated.

TEMA AEW

Description: Removable tube bundle, one or two-pass design □ double packed floating tubesheet with "O" rings and threaded retainer with telltale holes for leak detection □ shell sizes from 6" to 42" □ pressure range – 75 psi to 600 psi.

Applications: Lube oil coolers □ jacket water coolers □ aftercoolers.

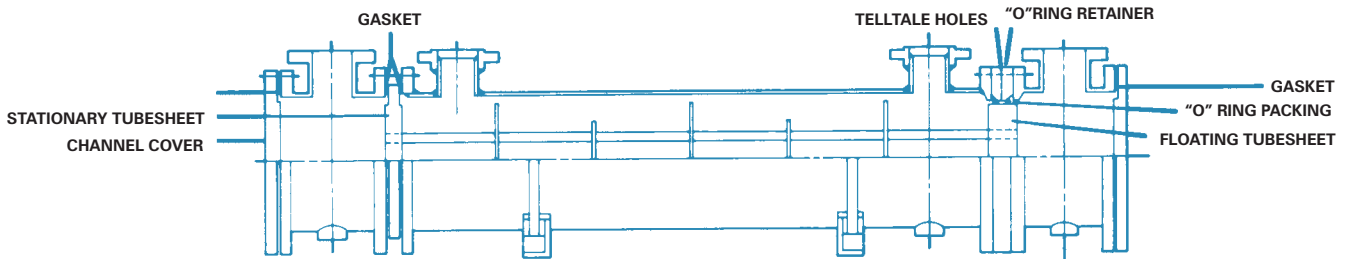

Advantages:

1. Highly efficient heat transfer – small annulus between outer tube limit (O.T.L.) and shell I.D.
2. Threaded "O" ring retainer permits tube inspection and cleaning without releasing shellside pressure.
3. Leaks easily detected – mixing or contamination of fluids eliminated.
4. Channel covers and return heads are easily removable for bundle inspection and cleaning.
5. Because of full thickness metal of "O" ring retainer, possibility of overtightening bolts and resultant "O" ring damage is eliminated.

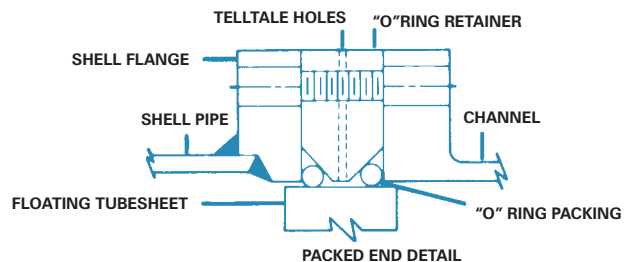

Limitations:

1. Should not be used for explosive or lethal fluids where packing leak cannot be tolerated.
2. One or two-pass configuration only.

Custom Designs

Description: Removable pull through bundle, high pressure closure, double shell, hairpin design □ Siller floating ring closure □ "O" ring packing, retainer and split ring seal shell and tubesheet assembly – permits bundle removal from reversing bonnet end □ pressure range – 1200 psi to 6000 psi tubeside and 150 psi shellside.

Applications: High pressure gas-in-the-tube.

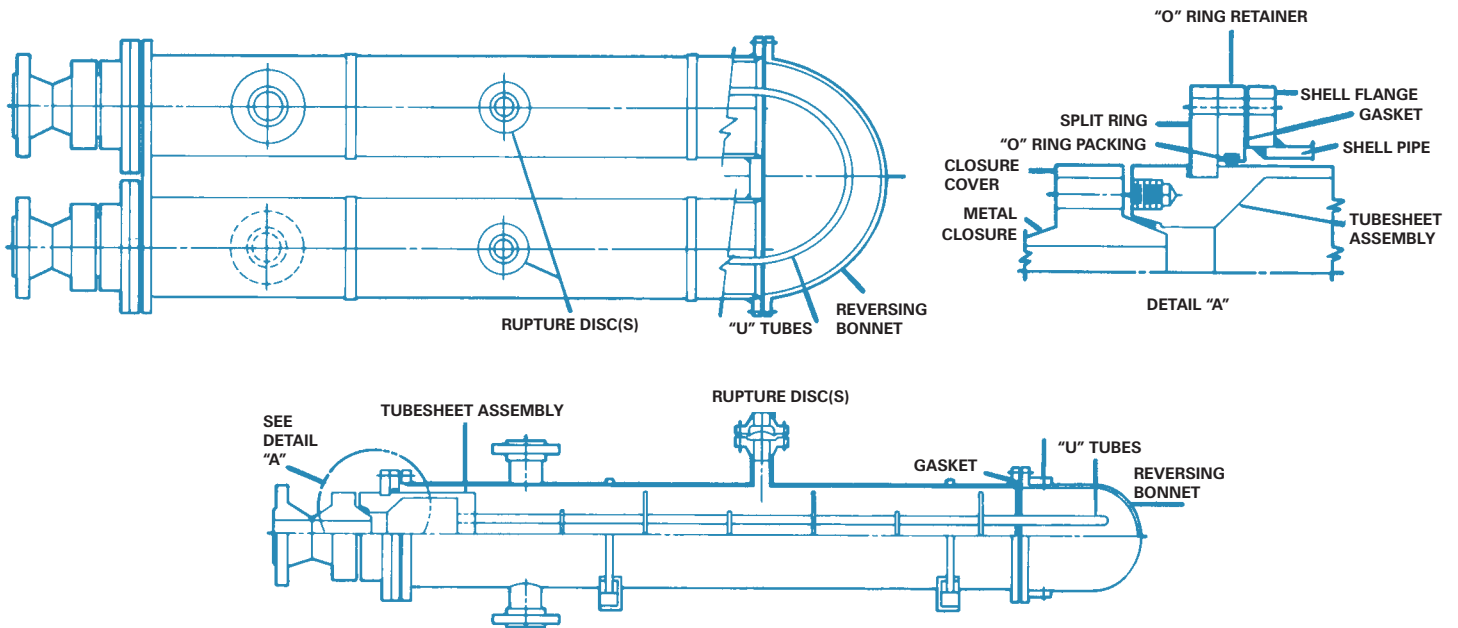

Advantages:

1. Replaces several "double pipe" sections in high pressure applications.
2. High heat transfer efficiency due to small annulus between outer tube limit (O.T.L.) and shell I.D.
3. Maximizes tube count and heat transfer service in given shell size.
4. Water and gas sealed off with two separate gaskets and two sets of bolts.
5. Desirable for applications which impose shell length limitations.
6. Tube bundle easily removable for cleaning or inspection.

Limitations:

1. Outer tube rows must be removed before replacing inner rows.
2. Requires chemical cleaning.
3. May not be advisable for use where tubeside fouling is anticipated.

Description: Custom Basco high pressure exchanger □ removable pull through tube bundle, high pressure closure, floating head, outside packed □ special Siller floating ring closure □ standard square neoprene packing used between floating tubesheet and shell flange.

Applications: High pressure gas-in-the-tube.

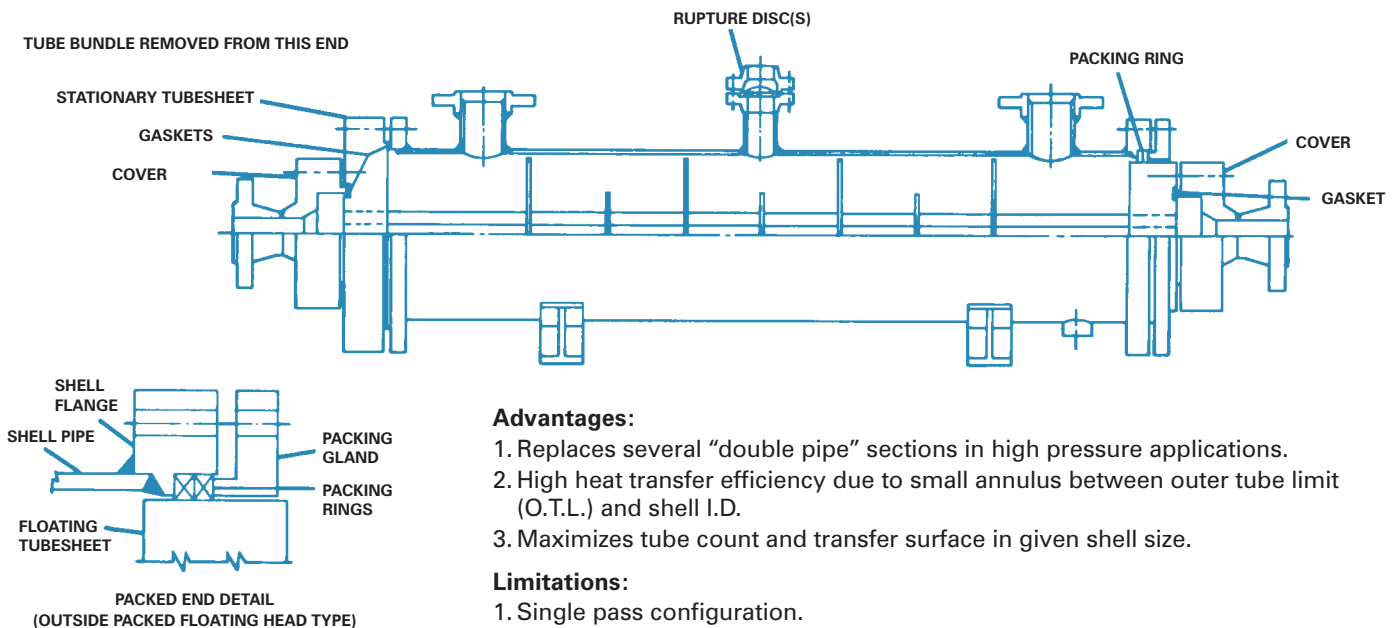

Advantages:

1. Replaces several "double pipe" sections in high pressure applications.
2. High heat transfer efficiency due to small annulus between outer tube limit (O.T.L.) and shell I.D.
3. Maximizes tube count and transfer surface in given shell size.

Limitations:

1. Single pass configuration.

API Heat Transfer

API Heat Transfer Inc.
2777 Walden Avenue
Buffalo, New York 14225
(716) 684-6700
www.apiheattransfer.com

Divisions:

API Airtech ISO-9001 Certified

Air Cooled Aluminum Heat Exchangers

91 North Street • P.O. Box 68
Arcade, New York 14009-0068
(585) 496-5755 • Fax: (585) 496-5776

API Basco ISO-9001 Certified

Basco®/Whitlock® Shell & Tube Heat Exchangers

2777 Walden Avenue
Buffalo, New York 14225
(716) 684-6700 • Fax: (716) 684-2129

API Schmidt-Bretten Americas

Plate Heat Exchangers and Thermal Systems

2777 Walden Avenue
Buffalo, New York 14225
(716) 684-6700 • Fax: (716) 684-2129

API Schmidt-Bretten GmbH & Co. KG

ISO-9001 Certified

Plate Heat Exchangers and Thermal Systems

Langenmorgen 4
D-75015 Bretten, Germany
(49)725253-0 • Fax: (49)725253-200

API Heat Transfer (Suzhou) Co., Ltd.

Air Cooled Aluminum Heat Exchangers

Shell & Tube Heat Exchangers

Plate Heat Exchangers

156 Qingqiu Street, 3rd District
Suzhou Industrial Park
Suzhou, Jiangsu 215126 China
(86)512-88168000 • Fax: (86)512-88168003

Contact your local API Sales Representative

or API Heat Transfer directly

toll-free: 1-877-API-HEAT

e-mail: sales@apiheattransfer.com

Other Products Available from API Heat Transfer

Gasketed Plate Heat Exchangers



The Schmidt line of gasketed plate & frame heat exchangers provide excellent heat transfer in a compact space. Plates are pressed from stainless steel, titanium and other alloys. Gaskets of nitrile, EPDM, Viton®, compressed fiber and Teflon® are used. Capacities range from 0.5 to 10,000 GPM.

Semi-Welded Plate Heat Exchangers



Combines the high thermal efficiency, compact design, and low volumetric liquid hold-up of a plate heat exchanger with the leak prevention of a shell & tube. Ideal for ammonia applications.

Air-Cooled Heat Exchangers

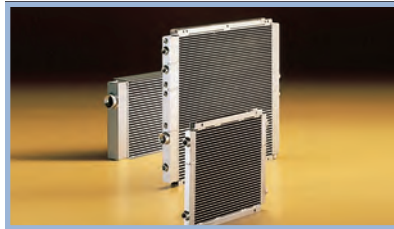

High efficiency, brazed aluminum coolers for cooling a wide variety of liquids and gases with ambient air. Lightweight, yet rugged. Capable of cooling multiple fluids in single unit. Models can be supplied with cooling fan and a variety of drives.

SigmaStar® Evaporator Systems



Utilizing the SigmaStar® plate, this evaporator system is designed to remove water or other solvents, while concentrating solutions. SigmaStar® Systems can be pre-assembled and pre-tested prior to shipment for quick and easy start up.

Welded Plate Heat Exchangers

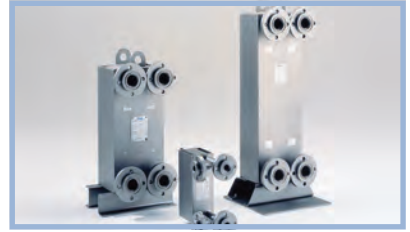

The Sigmawig all-welded plate heat exchanger has operating temperatures as high as 750° F and as low as -320° F, and operating pressures as high as 360 PSI. The unique concept of this rugged heat exchanger makes it a viable solution for many heat transfer needs previously thought only suitable for shell & tube designs.

Extended Surface



Unique, patented plate-fin design for centrifugal or axial compressor intercooler and aftercooler applications and minimal pressure loss. Design eliminates separators. ASME code design is standard. Diameters from 20" (50.8 cm) to 144" (365.76 cm).

Hubbed Shell and Tube Heat Exchangers



Straight or U-tube, fixed or removable tubesheet general purpose exchangers designed to cool oil, water, compressed air and other industrial fluids. A variety of port configurations and materials are available. Diameters from 3" (7.62 cm) to 12" (30.48 cm).

Genuine Manufactured Parts

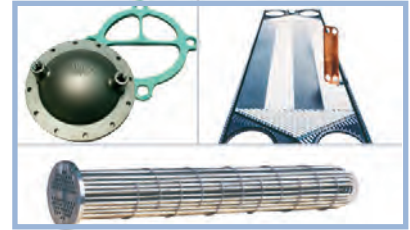

Contact API Heat Transfer to order all your replacement parts. Only genuine parts manufactured to the original specifications of your heat exchanger will ensure proper performance. Many items such as gaskets, bonnets, and PHE thermal plates are available from stock.